

DOI:

ABSTRACT

The main purpose of this paper is to present a control system which will cause better alignment of Photo voltaic (PV) array with sun light and to harvest solar power. The proposed system changes its direction in two axis to trace the coordinate of sunlight by detecting the difference between position of sun and panel. Hardware testing of the proposed system is done for checking the system ability to track and follow the sunlight in an efficient way. Dual axis solar tracking system superiority over single axis solar tracking system is also presented.

KEYWORDS: solar, tracker, irradiance, dual axis, dc motor, single axis.

INTRODUCTION

Solar energy is a very large, inexhaustible source of energy. The power from the sun intercepted by the earth is approximately (1.8×10^{11}) MW, which is many thousands of times larger than the present consumption rate on the earth of all commercial energy sources. Problem associated with the use of solar energy is that its availability varies widely with time. The variation in availability occurs daily because of the day night cycle and also seasonally because of the earth's orbit around the sun. To rectify the problems the solar panel should be such that it always receives maximum intensity of light. It has been seen since past that the efficiency of the solar panel is around 10-15% which is not meeting the desired load requirements. So there is a need of improving the panel efficiency through an economical way. The existing tracking systems based on sensing elements, stepper motors etc have some disadvantages of their kind. A well designed solar tracking system overcoming all the disadvantages of the models discussed above is necessary in order to improve the efficiency of the panel in a most economical way.

Solar Tracking System:

A Solar tracker is an automated solar panel which actually follows the sun to get maximum power. Even though a fixed flat-panel can be set to collect a high proportion of available noon-time energy, significant power is also available in the early mornings and late afternoons when the misalignment with a fixed panel becomes excessive to collect a reasonable proportion of the available energy. For example, even when the sun is only 10° above the horizon the available energy can be around half the noon-time energy levels (or even greater depending on latitude, season, and atmospheric conditions). Thus the primary benefit of a tracking system is to collect solar energy for the longest period of the day, and with the most accurate alignment as the sun's position shifts with the seasons.

Types of Trackers

Solar trackers are grouped under two basic categories the single axis trackers and the dual axis trackers. The single tracker rotates east to west following the sun's movement, and the dual trackers include vertical and horizontal movements i.e. they can incline or tilt to account for winter and summer sun angles.

In section II, discussion about literature work that supporting components to design dual axis solar tracker.

Microcontroller:

It is the major part of the system. The microcontroller controls all the operations. The solar panel is aligned according to the sun position algorithm under the control of the microcontroller.

Dc motor:

Interfacing a dc motor with a microcontroller, usually H- bridge is preferred way of interfacing a dc motor. These days many IC manufacturers have H-bridge motor drivers available in the market like L293D, MC33926 are most used H-Bridge driver IC. H- Bridge can also be made with the help of transistors and mosfets etc. rather of being cheap; they only increase the size of the design board, which is sometimes not required so using a small 16 pin IC is preferred for this purpose.

Motor Driver Circuit :

The L293D is a monolithic integrated high voltage, high current four channel driver designed to accept standard DTL or TTL logic levels and drive inductive loads (such as relays solenoids, DC and stepping motors) and switching power transistors. The speed of DC motor can also be controlled with MCU. PWM or pulse width modulation technique is used to digitally control speed of dc motors.

Relays:

Relays are used where it is necessary to control a circuit by a low-power signal (with complete electrical isolation between control and controlled circuits), or where several circuits must be controlled by one signal. Here the relays are used to dc motors.

BLOCK DIAGRAM

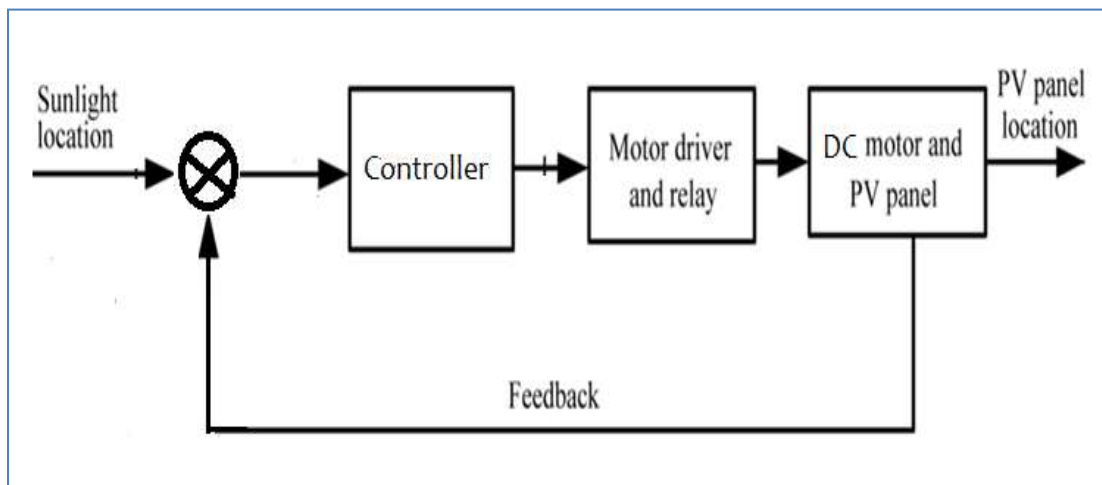

Figure 1 Block diagram of dual axis solar tracking system

Here sun position can be calculated from sun position algorithm and panel position can be calculated from angle sensors connected to the tracker. Here the sun position and pv panel position both are given as input to the microcontroller which will rotate the panel to a exact position through the dc motor with help of motor driver and relay. To get exact tracking a logic is followed with the flow of signal with microcontrollers and IC's. The flow of signal is shown in below block diagram. The microcontroller is interfaced to real time clock and lcd display and to motor through driver .

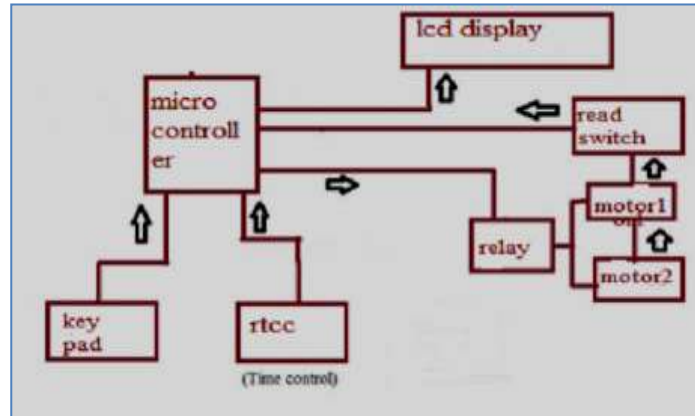

Figure 2 Block diagram of solar tracker control

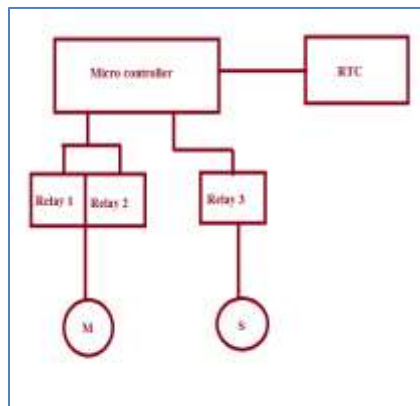

Figure 3 motor control and its interfacing circuit

The relays are used to control the dc motors which are inbuilt in actuator. The relay 1 is operated whenever the motor should run clockwise direction and similarly relay 2 works when motor should run in anti-clockwise direction. A switch is also connected to the micro controller with a sensing relay. The use of it is whenever the micro controller gets off it becomes difficult to it to trace the position of panel once it is switched ON, so a switch is provided. After controller is ON, the panel will keep tilting until it touches the switch and once the switch is closed the controller senses that the panel is at zero position, now it reads the time from RTC and sets the panel according to the time.

EXPERIMENTAL SETUP



Figure 4 Solar tracking set up

Change of panel position with daily sun variation has been shown in the figure4 at morning and afternoon and evening time. Tracker is also moving its position with respect to the sun.

EXPERIMENTAL RESULTS

The sun position that is azimuth and altitude position of sun are shown in **figure5** and **figure6** which are calculated from SPA (sun position algorithm).

« Friday, 15th April 2016 »		
Time (24 hr)	Azim.	Alt.
06:00	80°	-1°
06:15	81°	3°
06:30	82°	6°
06:45	83°	10°
07:00	84°	13°
07:15	85°	17°
07:30	86°	20°
07:45	87°	24°
08:00	88°	28°
08:15	89°	31°

Figure 5 Azimuth and Altitude angle of sun

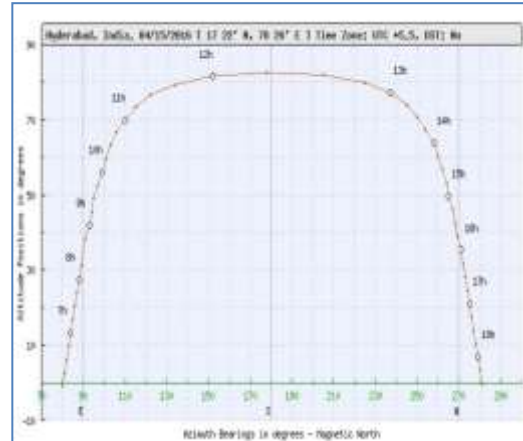

Figure 6 sun position graph

Experiments results were performed by placing the designed system in open air. Figure 7and 8 show the output power for PV systems (Single axis tracking and dual axis tracking). These observations were performed on 15 April 2016 . The output power data is collected during 8:00 AM to 9:00 PM that are obtained through scada.

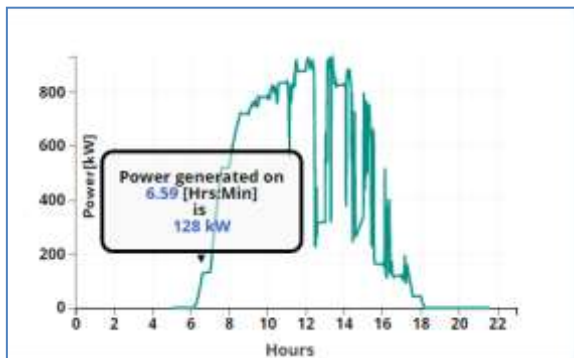

Figure 7 output power of single axis solar tracker

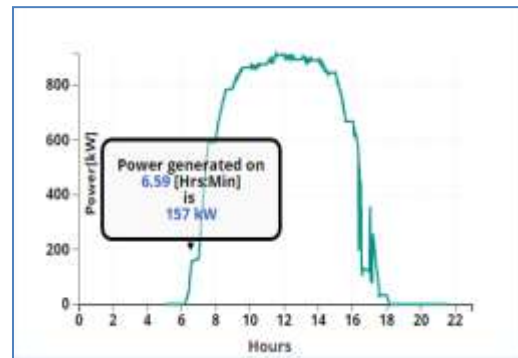

Figure 8 output power of dual axis solar tracker

From figure 7 and 8 the power generated for single axis tracker is 128kw and for dual axis tracker is 157kw at 6.59am.the experimental results clearly show that dual axis tracking is superior to single axis tracking. Power captured by dual axis solar tracker is high during the whole observation time period.

CONCLUSION AND FUTURE SCOPE

Conclusion:-

A pre-determined solar tracking system has been designed economically using motorized linear actuator. The proposed overall solar tracking system design was tested, based on calculated data of the altitude angle of hyderabad. The obtained system response results show the simplicity, accuracy and applicability of design in meeting different operational conditions.

Future Scope:-

The motor controller can be extended by improving the accuracy of the circuit and detailed study on the location. The irradiation calculation also plays a vital role so there is a need of adding it to the project which can be extended. we have used mono crystalline pv panel for our research study. however we can use poly crystalline material based pv panel for this purposed model and material based comparison of both systems can be done.

REFERENCES

- [1] http://en.wikipedia.org/wiki/Solar_tracker
- [2] D. Appleyard, "Solar Trackers: Facing the Sun," Renewable Energy World, Vol. 12, No. 3, 2009. <http://www.renewableenergyworld.com/rea/news/article/2009/06/solar-trackers-facing-the-sun>
- [3] <http://www.solar-tracking.com/>
- [4] N. Barsoum and P. Vasant, "Simplified Solar Tracking Prototype," Global Journal of Technology and Optimization GJTO, Vol. 1, 2010, pp. 38-45.
- [5] Bajpai, P.; Kumar, S. Design, Development and Performance test of an Automatic Two-Axis Solar Tracker System. In Proceedings of 2011 Annual IEEE India Conference, Hyderabad, India, 16–18 December 2011; pp. 1–6.
- [6] <http://chargeursolaire.over-blog.com/article-the-working-principle-of-solar-tracking-controller-63106485.html>
- [7] <http://www.hindawi.com/journals/jre/2014/629717/>
- [8] Nader Barsoum, "fabrication of Dual-axis solar tracking controller project", intelligent control and automation 2011, 2, 57-68.
- [9] Serhan, M.; El-Chaar, L. Two Axis Sun Tracking System: Comparison with a Fixed System. In Proceedings of International Conference on Renewable Energies and Power Quality, Granada, Spain, 23–25 March 2010.